

Gas Discharge Tube: GD8 Series



2-Electrode $\Phi 8.0$ x T6 mm High Surge Type

■ Features

1. RoHS & HF compliant
2. Rugged ceramic-metal construction
3. Available with or without leads
4. DC spark-over voltage: 70~800V
5. Low capacitance
6. Agency recognition: UL / cUL
7. Operating temperature: $-40^{\circ}\text{C} \sim +105^{\circ}\text{C}$
Storage temperature: $-40^{\circ}\text{C} \sim +115^{\circ}\text{C}$



■ Recommended Applications

1. Cable modem
2. xDSL
3. Set-top box
4. TV sets
5. Power supply
6. Consumer electronics

■ Part Number Code

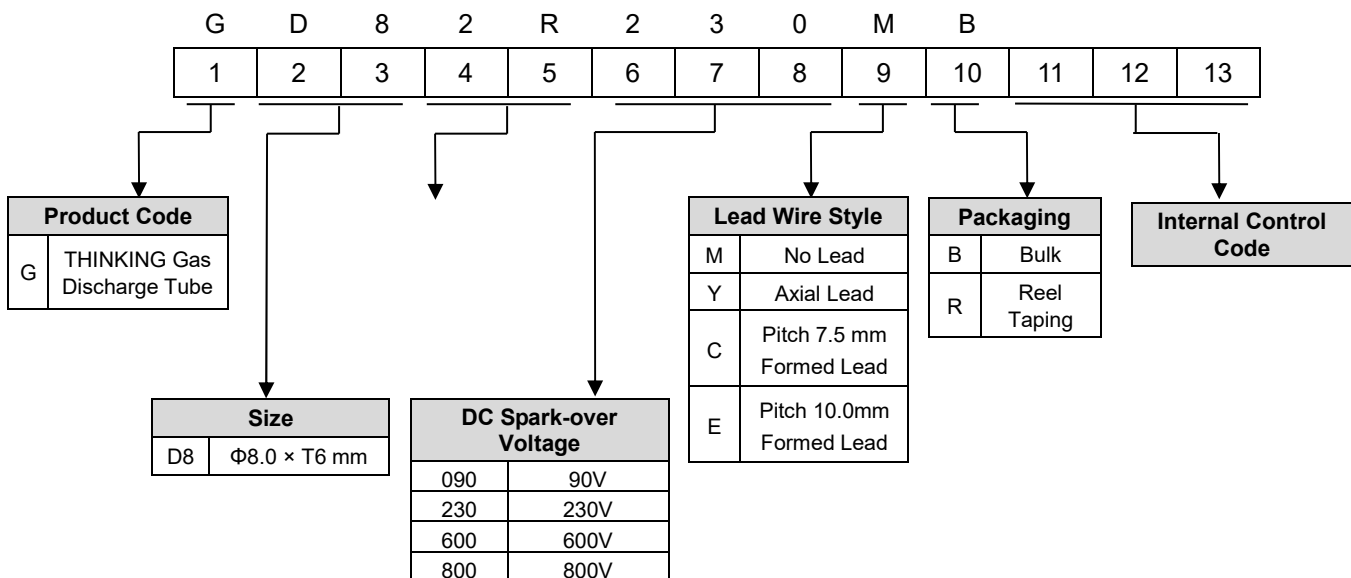

Gas Discharge Tube: GD8 Series



2-Electrode $\Phi 8.0$ x T6 mm High Surge Type

■ Characteristics

Part No.	DC Spark-over Voltage	Max. Impulse Breakdown Voltage		Max. Impulse Discharge Current (8/20 μ s)		Impulse Life (10/1000 μ s)	Normal Alternating Discharge Current	DC Holdover Voltage	Minimum Insulation Resistance	Maximum Capacitance (1MHz)	Safety Approvals	
	100V/S	100V/ μ s	1KV/ μ s	1 time	10 times	100A	50Hz, 1Sec	<150ms			UL14 49/ cUL	UL 497B
	(V)	(V)	(V)	(KA)		(Times)	(A)	(V)				
GD82R090□□	90 \pm 20%	500	600	20	15	500	10	52	1	1.5		√
GD82R120□□	120 \pm 20%	500	700					52			√	
GD82R130□□	130 \pm 20%	500	700					52			√	
GD82R145□□	145 \pm 20%	500	700					52			√	
GD82R230□□	230 \pm 20%	500	700					80			√	
GD82R250□□	250 \pm 20%	500	700					135			√	
GD82R300□□	300 \pm 20%	700	900					150			√	
GD82R350□□	350 \pm 20%	700	900					150			√	
GD82R400□□	400 \pm 20%	800	1000					150			√	
GD82R470□□	470 \pm 20%	900	1100					150			√	
GD82R600□□	600 \pm 20%	1100	1300		√	√						
GD82R800□□	800 \pm 20%	1300	1500	15	10	500	5	150		√	√	
GD82R10B□□	1000 \pm 20%	1700	2000	15	10	500	5	150		√		

Note1: The first □ is style of lead wire, and the second □ is packaging.

Note2: UL 497B File No: E245070, UL 1449 4th File No:E314979

Note 3: Insulation resistance test conditions:

DC Spark-over Voltage	DC Measuring Voltage
90-150V	50V
151-400V	100V
401-1000V	250V
1001-2000V	500V
>2001V	1000V

Gas Discharge Tube: GD8 Series



2-Electrode $\Phi 8.0$ x T6 mm High Surge Type

Dimension

□ = Y (Axial Lead Type)

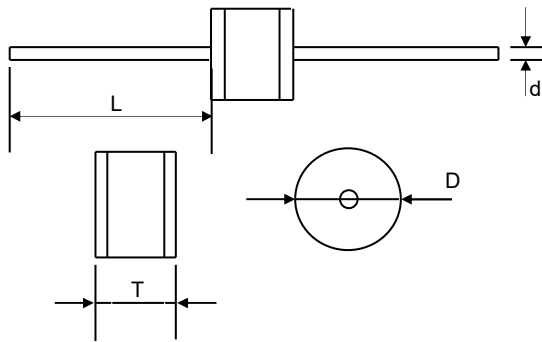

(Unit: mm)

Item	Dimensions	
	Spec.	Tolerance
D	8.0	+0.3/-0.5
T	6.0	+0.3/-0.5
L	20	Min.
d	0.8	± 0.05

□ = M (No Lead Type)

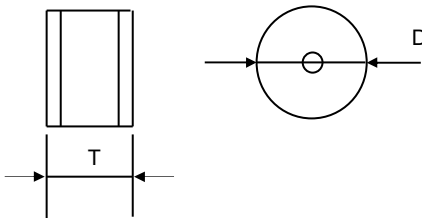

(Unit: mm)

Item	Dimensions	
	Spec.	Tolerance
D	8.0	+0.3/-0.5
T	6.0	+0.3/-0.5

□ = C, E (Formed Lead)

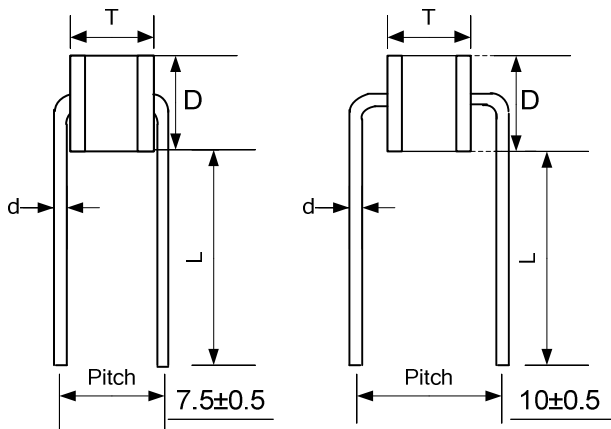

(Unit: mm)

Item	Dimensions	
	Spec.	Tolerance
D	8.0	+0.3/-0.5
T	6.0	+0.3/-0.5
d	0.8	± 0.5
L	15.0	Min.
	7.5	± 0.5
P	10	± 0.5

Marking

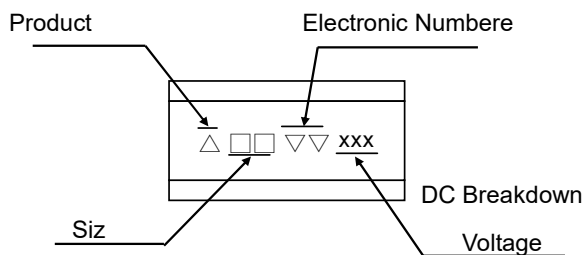

Example

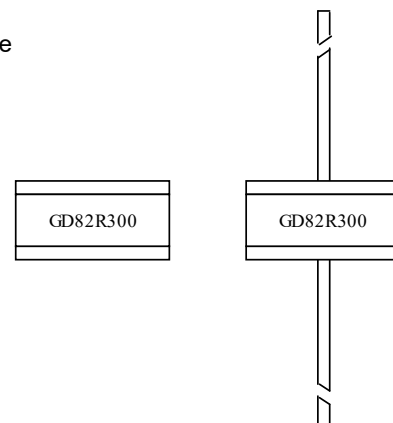

Gas Discharge Tube: GD8 Series

2-Electrode $\Phi 8.0$ x T6 mm High Surge Type



■ Packaging

● Bulk

- ◆ For No Lead (M Type) and Axial Lead (Y Type):

Quantity: 100pcs per PVC Box, 500pcs per Inner Box

Quantity (MPQ): 500pcs

- ◆ For Formed Lead (C, E Type) :

Quantity: 100pcs per PVC Box, 500pcs per Inner Box

Quantity (MPQ): 500pcs

● Taping

For 2-electrode Axial Lead GDT: 500 PCS/Reel

Quantity (MPQ): 500pcs

(Unit: mm)

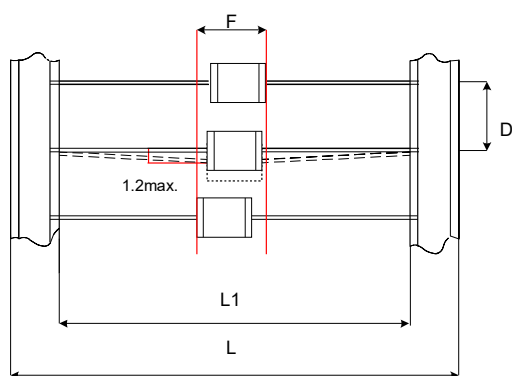

Item	Dimensions	
	Spec.	Tolerance
L1	52	± 2
L	64	± 3
D	10	± 0.5
F	T + 1.4	Max.

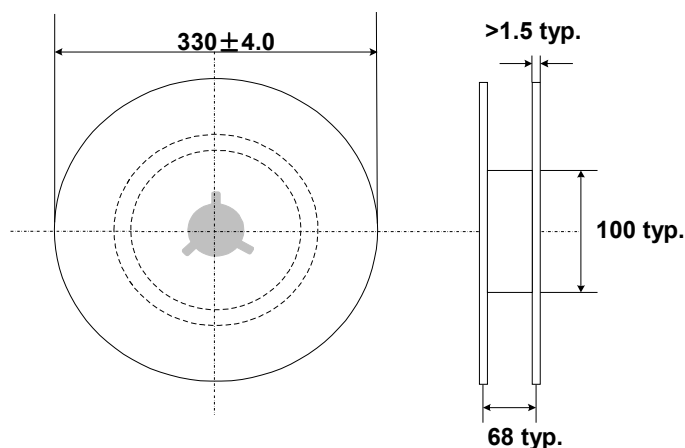

Warehouse Storage Conditions of Products

● Storage Conditions:

1. Storage Temperature: $-10^{\circ}\text{C} \sim +40^{\circ}\text{C}$
2. Relative Humidity: $\leq 75\% \text{RH}$
3. Keep away from corrosive atmosphere and sunlight.